

# ROBINAIR FLUID PRODUCTS

## A/C Tools & Accessories

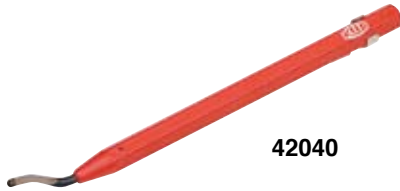

### Single Blade Deburring Tool

This handy tool removes internal burrs in copper tubing. It features a high-speed steel, blade, aluminum handle, and pocket clip. Tubing size is unlimited.

**No. 42040** – Single blade deburring tool.



### Deburring Tool

Quickly deburrs aluminum, copper, and steel tubing, and can work on any size tubing. It's made with a high-speed, steel blade and a durable aluminum handle. Three spare blades store in the handle.

**No. 13162** – Deburring tool.

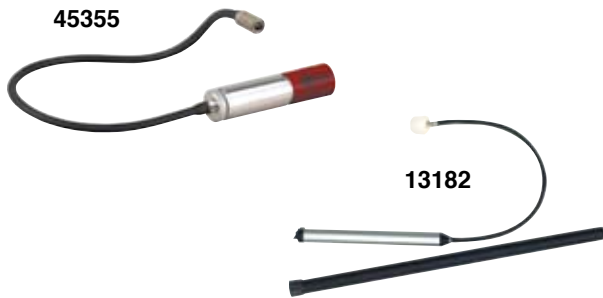

### Fiber Optics Inspection Light

The applications for this handy tool are practically endless...check burners on heat exchangers for cracks, check coils for dirt and damage, look at serial numbers, fan motor tags, etc., on furnaces and condensing units. Fiber optics provide a bright light, but the shaft is just 7.6 mm in diameter. A durable cover fits over the 15" flexible shaft for protection. Powered by three AA batteries.

**No. 13182** – Fiber optics inspection light.

**No. 45355** – Inspection light with magnetic tip and base.



### A/C Clutch Pulley Puller Set

- For removal of stubborn air conditioning clutch pulleys. Also used on many alternator, generator, power steering, and crankshaft pulleys, harmonic balancers, and fiber timing gears.
- Set includes drop-forged components: one 3/4"-16 x 5" live-center forcing screw, 5-1/2" crossbar with three spread settings, two pairs of jaws, and a clamp bolt.
- Spread: 3" to 5"; Reach: 1" to 5".
- Includes blow-molded plastic case.

**No. 4536** – A/C clutch pulley puller set.

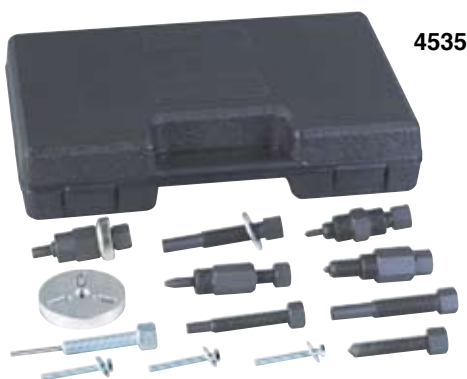

### A/C Clutch Hub Remover/Installer Set

- For damage-free removal and installation of the clutch hubs on these air conditioning compressors: GM-Harrison DA-6, HR-5, V-5, A-6, and early R4; Nippondenso Ford/Chrysler A590, C171, FS-6, 6P148A (new style); Sanden & Sankyo; York/Tecumseh HR980; Zexel/Mitsubishi CH series.
- Set includes a removing flange, plus forcing screws and adapter assemblies to remove and install virtually all clutch hubs.
- Includes blow-molded plastic case.

**No. 4535** – A/C clutch hub remover/ installer set (13 pc.).



### Clutch Plate Remover

Designed to overcome resistance when removing the clutch plate.

**No. 11009** – Clutch plate remover.

# ROBINAIR FLUID PRODUCTS

A/C Tools & Accessories

## Spring Lock Coupler Disconnect Set

Set includes four sizes for use on 3/8", 1/2", 5/8", and 3/4" tubes. Allows quick, safe disconnect of spring lock couplers on late model Ford systems and Tecumseh HR980 compressors.

**No. 7238** – Spring lock coupler disconnect set.

7238



## Fuel Line Disconnect Tool

Special low-profile design works in close quarters on GM, Ford, and Chrysler vehicles where there is limited clearance between the fuel line fittings and fuel filters, fuel rails, or sending units. This tool is designed to access the center port on the GM fuel tank sending unit.

For 3/8" and 1/2" applications; will also service 2001 thru current 3/4- and 1-ton trucks with the Duramax Diesel engine.

**No. 6511** – Fuel line disconnect tool.

6511



## Clutch Plate Remover/Installer

These compact tools are used both to remove the clutch for access to the shaft seal and to re-install it by simply inverting the nut and main bearing.

**No. 10861** – A6, R4. **No. 41067** – V5, DA6, HR6.

10861



## Compressor Turning Tool

Works on wide variety of compressor models. Fits clutch hubs that do not have holes that a spanner wrench can grip, or a hex end that a box wrench can grip. Spreads lubrication to prevent compressor damage at start-up. Recommended by OE compressor manufacturers.

- Threads into most hex-less clutch hubs.
- Uses a standard 19mm (3/4") wrench.
- Allows technician to check for internal damage.
- Breaks compressor lock-up due to sticky protective coatings.
- Turns compressor in the direction of normal rotation.

**No. 41057** – Compressor turning tool.

41057



Patent Pending

## A/C Clutch Holding Tool

This three-stud spanner wrench keeps the A/C clutch from turning when loosening or tightening the retaining nut. Adjusts quickly with brass thumbscrews to fit various styles of A/C compressors used on GM, Ford, and Chrysler vehicles. Also fits a variety of other pulleys.

**No. 4537** – A/C clutch holding tool.

4537



## Four-In-One Tube Bender

Effortlessly bends four different sizes of soft or annealed tubing without crimping, flattening, or scratching. Calibration allows duplication of any angle. Handles are 8-1/2" long, so extensions are not needed, and glass/plastic construction combines strength with lightweight durability.

**No. 18548** – Tube bender for 3/16", 1/4", 5/16", and 3/8" tubing.

18548



## Fin Straightener

Use our handy six-in-one straightener to clean and straighten condenser and evaporator coil fins. Straightener sections are clearly marked for fin size. The tool is compact enough to use even in confined spaces: the straightener head is 3-1/8" in diameter; the handle is 3-1/2" long.

**No. 18403** – Fin straightener – 8, 9, 10, 12, 14, & 15 fins per inch.

18403

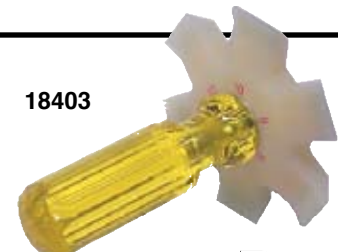

ROBINAIR