

10/18/04

EZ-3/4/5/9 REAR MOUNTING

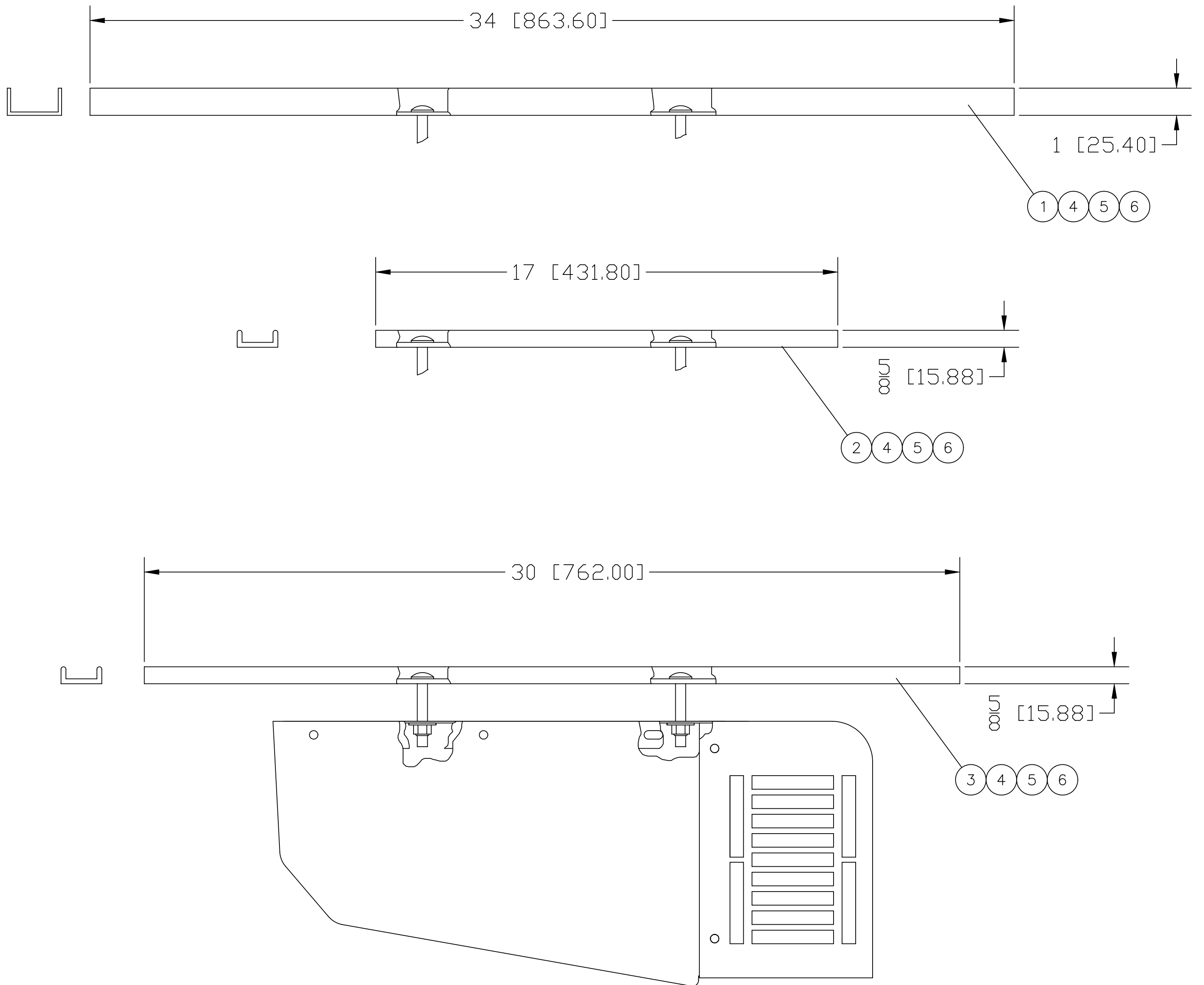

ITEM	PART NUM	DESCRIPTION	QTY
1	200-048-W	MOUNTING CHANNEL,HEAVY DUTY,WHITE,34" LG	2
		****NO HOLES****	
2	200-010	MOUNTING CHANNEL,EZ-3/4/5 EVAP,17" LONG	2
3	200-216	MOUNTING CHANNEL,30 LONG,EZ-3/4/5/9 EVAP	2
4	CHB3816400Z	BOLT,CARRIAGE HEAD,3/8-16 X 4 ZINC	4
5	FLW38Z	WASHER,FLAT,3/8 ZINC	4
6	NHL3816Z	NUT,HEX LOCK,3/8-16 ZINC	4

10/18/04

EZ-3 SIDE MOUNTING

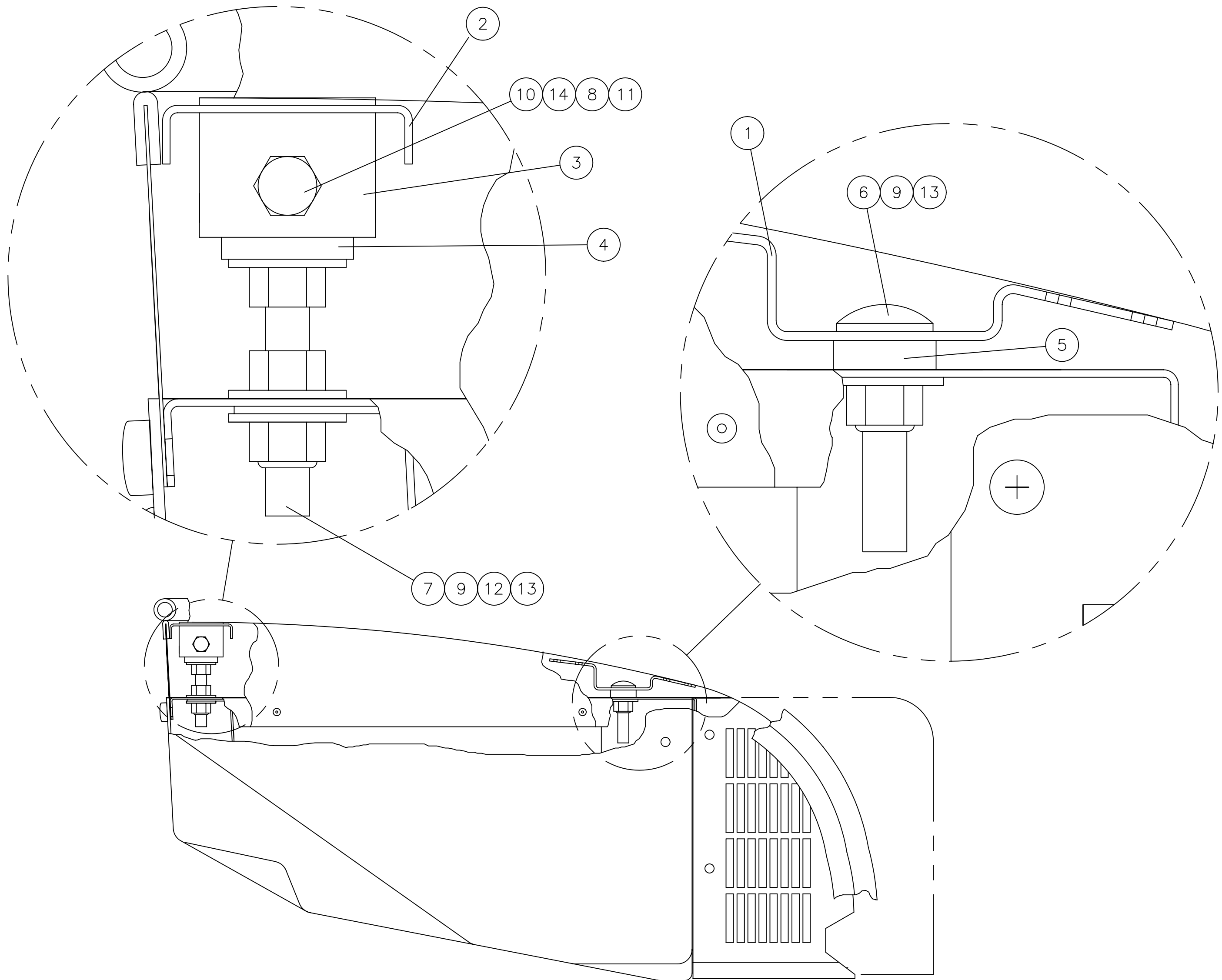

ITEM	PART NUM	DESCRIPTION	QTY
1	210-066	MOUNTING BRACKET,REAR,SIDE MOUNT EVAP	1
2	210-060	MOUNTING BRACKET,FRONT,SIDE MOUNT EVAP	1
3	210-025	PIVOT,FRONT MOUNTING BRACKET	2
4	210-026	MOUNTING PLATE,FRONT MOUNTING BRACKET	2
5	SPC-004	SPACER,7/8 X 1/2 X 1/4THK	2
6	CHB3816200Z	BOLT,CARRIAGE HEAD,3/8-16 X 2 ZINC	2
7	CHB3816400Z	BOLT,CARRIAGE HEAD,3/8-16 X 4 ZINC	2
8	FLW31Z	WASHER,FLAT,5/16 ZINC	8
9	FLW38Z	WASHER,FLAT,3/8 ZINC	8
10	HXB3118075Z	BOLT,HEX HEAD,5/16-18 X 3/4 ZINC	4
11	HXN3118Z	NUT,HEX,5/16-18 ZINC	4
12	HXN3816Z	NUT,HEX,3/8-16 ZINC	4
13	NHL3816Z	NUT,HEX LOCK,3/8-16 ZINC	4
14	SLW31Z	WASHER,SPLIT,5/16 ZINC	4

EZ-4/5 SIDE MOUNTING

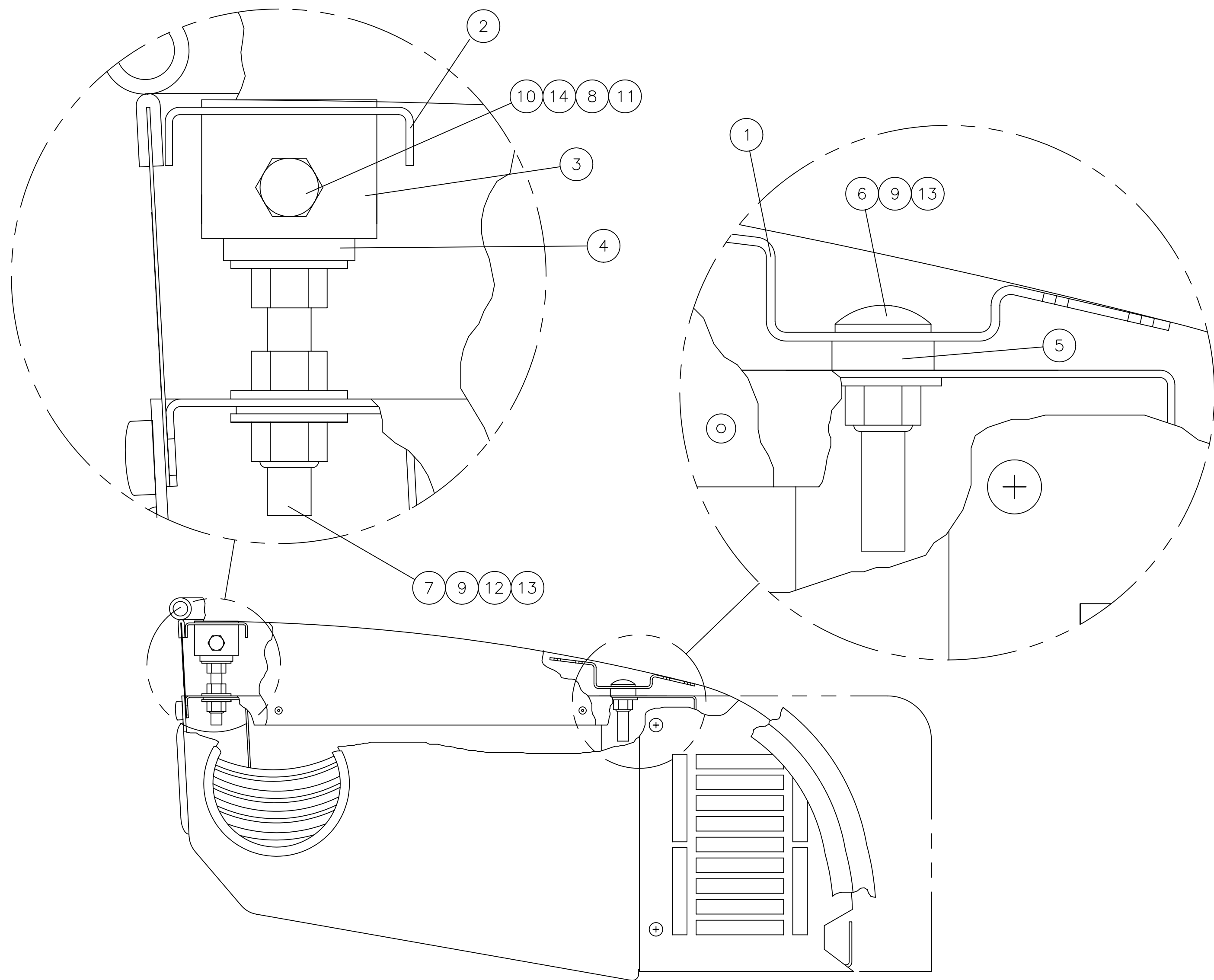

ITEM	PART NUM	DESCRIPTION	QTY
1	210-023	MOUNTING BRACKET,REAR,SIDE MOUNT EVAP	1
2	210-024	MOUNTING BRACKET,FRONT,SIDE MOUNT EVAP	1
3	210-025	PIVOT,FRONT MOUNTING BRACKET	2
4	210-026	MOUNTING PLATE,FRONT MOUNTING BRACKET	2
5	SPC-004	SPACER,7/8 X 1/2 X 1/4THK	2
6	CHB3816200Z	BOLT,CARRIAGE HEAD,3/8-16 X 2 ZINC	2
7	CHB3816400Z	BOLT,CARRIAGE HEAD,3/8-16 X 4 ZINC	2
8	FLW31Z	WASHER,FLAT,5/16 ZINC	8
9	FLW38Z	WASHER,FLAT,3/8 ZINC	8
10	HXB3118075Z	BOLT,HEX HEAD,5/16-18 X 3/4 ZINC	4
11	HXN3118Z	NUT,HEX,5/16-18 ZINC	4
12	HXN3816Z	NUT,HEX,3/8-16 ZINC	4
13	NHL3816Z	NUT,HEX LOCK,3/8-16 ZINC	4
14	SLW31Z	WASHER,SPLIT,5/16 ZINC	4